

24V Electro Mechanical Residential Double Swing Gate Motor Kit

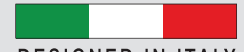

PREMIUM QUALITY



DESIGNED IN ITALY

- High quality, long-range transmitters
- Current sensing against physical stops
- Advanced Control Board (with display)
- Non-Reversing motors
- Solar friendly

Optional Extras:

- Extended arm (Black)
- Steel arm kit (Silver/Zinc)
- Limit switches
- Battery backup

What's Included:

- 2x Actuators (with mounting brackets)
- Control Board & Transformer in separate enclosure (inc. mains cable)
- 2x Coded hand transmitters



Patented anti pinch arm



Optional Extended Arm

- Suitable for longer leaves >2m
- Great for outswing application
- For use on large piers



<2m open



<4m open



24VDC

Low Voltage



No Welding Needed



Super Solar Friendly



External Transformer



Residential Application

TECHNICAL DATA

MOTOR POWER SUPPLY	24VDC
MAX. MOTOR POWER (W)	2 x 70
MAX. ABSORPTION (W)	3
DUTY CYCLE	CONTINUOUS

*For gate leaves exceeding 2m – an electric lock must be installed

**Max. gate leaf will depend on gate weight and wind load

(Contact Global Access For details)

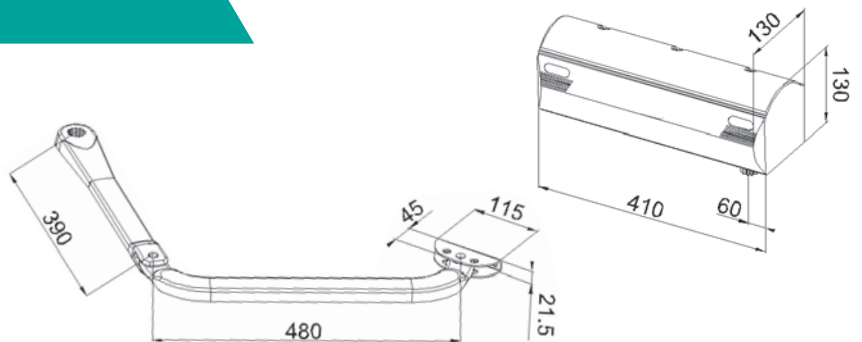

POPULAR ACCESSORIES (OTHER OPTIONS ARE AVAILABLE)



Electric Gate Lock



Safety Beams



4G Trigger Module



Keypads



Various Gate Hardware

Please contact us and we will be happy to assist you and discuss your application

1300 366 046 global-access.com.au