



**As strong
as a Bear!**
**Perfect for
heavy set
gates!**



FEATURES

- Easily adjusted inbuilt limit switches
- Virtually maintenance free operator with a long service life
- Gate and Post bracket can be screwed or welded as required
- Very quiet, smooth movement due to elastically supported threaded spindle
- Microprocessor control board with a range of setting options, such as: pedestrian mode, automatic closing, adjustable speed and early warning time, adjustable obstacle detection (either total or partial gate reversal)
- The operator is very reliable due to the patented gear saving brake system, even with extreme forces of greater than 1 tonne are applied, e.g. caused by wind load or vandalism

Technical Specification

Electric motor(s)	24V DC
Absorbed power	118W
Max torque	4500Nm
Max leaf length	6M***
Duty Cycle	40%

*For gate leaves exceeding 3m – an electric lock must be installed

**Max. gate leaf will depend on gate weight and wind load
(Contact Global Access For details)

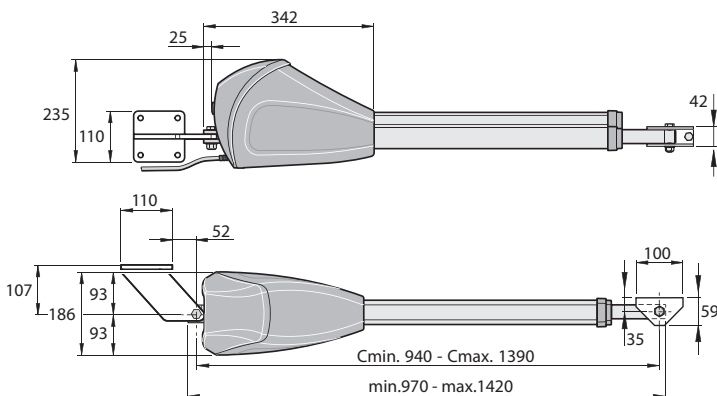

EASY TO ADJUST INBUILT LIMIT SWITCHES

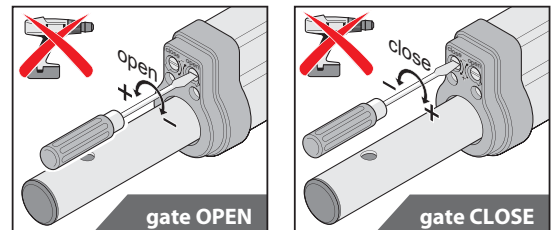

POPULAR ACCESSORIES



External Transformer



Safety Beams
to allow
auto-close



230V UPS Backup
for power outages



Electric solenoid
lock c/w latch plate



Maglock



Electric
Drop Bolt



Backlit Keypad
with fob reader
capabilities