

MAGIC BUTTON

MB ART PRO 24V

The MB ART PRO for domestic swing gates with a maximum length of 2.5m per leaf. The MB ART PRO 24V is designed for lightweight structures with large pillars.

The non reversing gear motor holds the gate in the open & closed positions and has built in mechanical stops.

Supplied and fitted under the cover with a Magic Button® control board with built in slow down features, provides for a fast installation and set up time.

A handy feature is their easily accessible manual unlocking mechanism so that the gates can be opened manually during electrical blackouts.

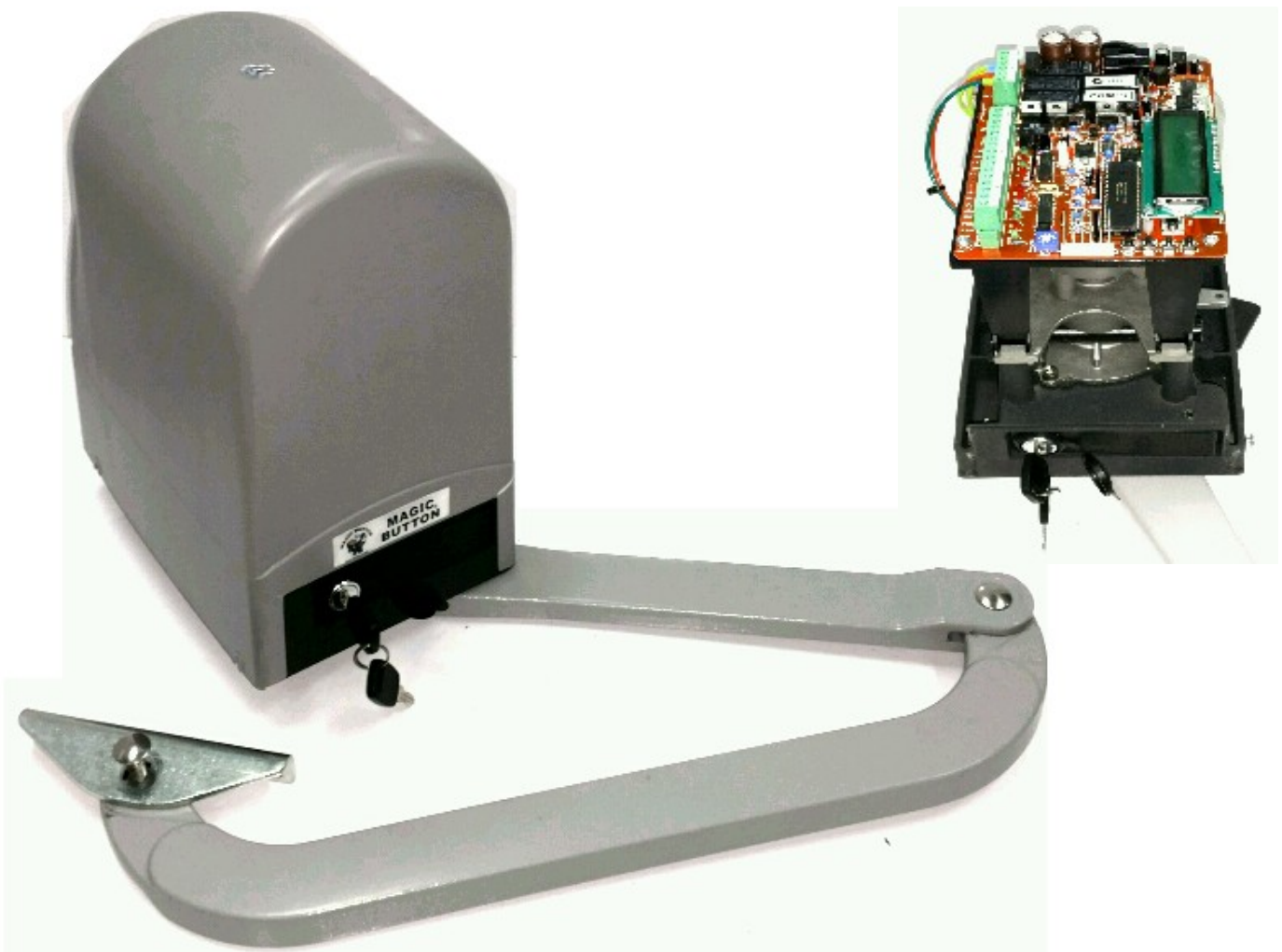



MAGIC BUTTON

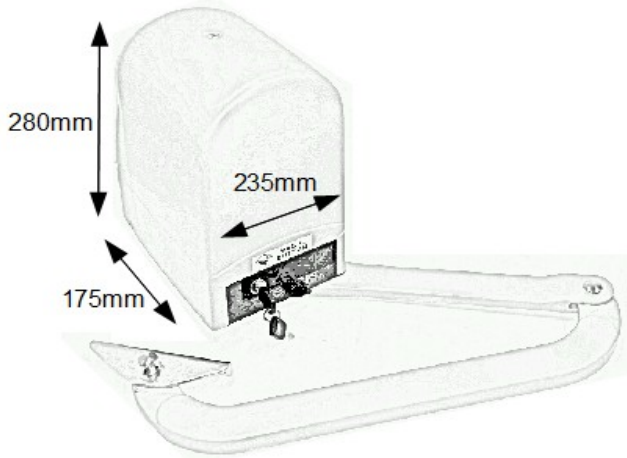

TECHNICAL FEATURES

TECHNICAL FEATURES

Power	24V dc
Protection level	IP44
Power (W)	80
Maximum thrust (N)	26
Opening time (sec)	13
Working temperature (°C Min/Max)	-20 / +50
Motor weight (kg)	10
Maximum leaf length (m)	2.5
RESIDENTIAL USE	

INSTALLATION LIMITS PER LEAF

1m	1.8m	2m	2.5m
300kg	250kg	220kg	200kg

The values shown above can be considerably reduced in windy areas.

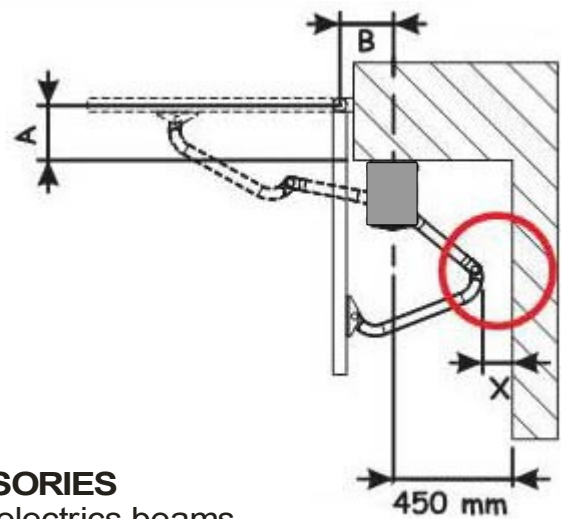
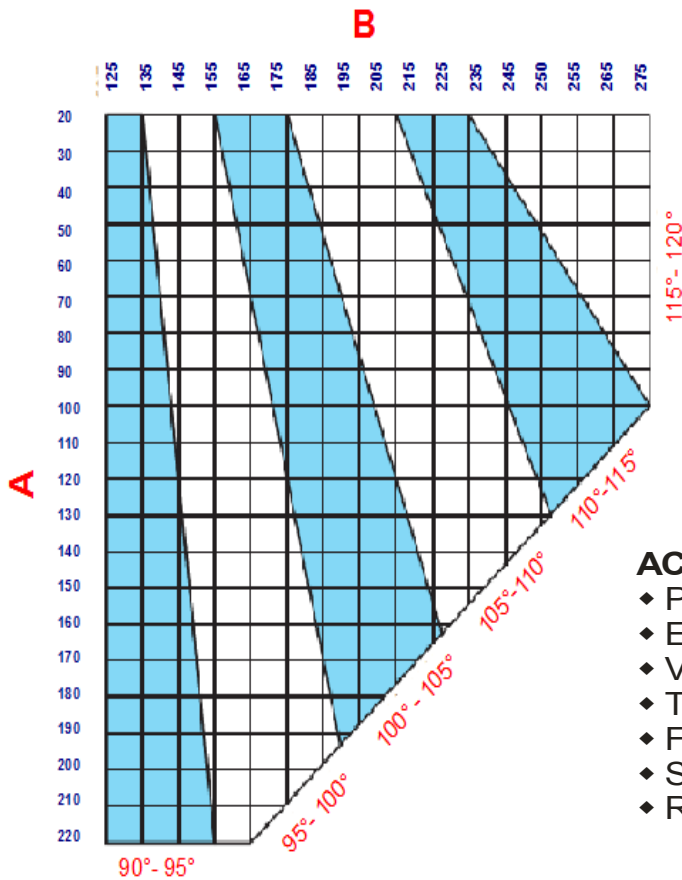

ACCESSORIES

- ◆ Photo electric beams
- ◆ Emergency stop controls
- ◆ Vehicle detectors
- ◆ Traffic lights
- ◆ Flashing lights
- ◆ Safety edge profile
- ◆ Radio & access control

NSW

Sydney (02) 9699 9654
Wollongong (02) 4256 4247

VICTORIA

QUEENSLAND

Brisbane (07) 3849 6666
Gold Coast (07) 5596 4795

LIFTMASTER ELECTRONICS PTY LTD A.B.N. 58 000 266 035
PO BOX 54 ALEXANDRIA NSW 1435 AUSTRALIA PH: 61 2 9699 9654 FX: 61 2 9699 8443
www.liftmaster.com.au salesdesk@liftmaster.com.au