

HEADQUARTERS

ITALY

FAAC SpA
Via Calari 10 - 40069 Zola Predosa (BO)
Tel. +39 051 61724 - Fax +39 051 758518
it.info@faacgroup.com - www.faacgroup.com

SUBSIDIARIES

AUSTRALIA

FAAC AUSTRALIA PTY LTD
Homebush – Sydney, Australia
tel. +61 2 87565644
fax +61 2 87565677
www.faac.com.au

AUSTRIA

FAAC GMBH
Salzburg, Austria
tel. +43 662 8533950
fax +43 662 85339525
www.faac.at

FAAC TUBULAR MOTORS

tel. +49 30 56796645
fax +49 30 22409006
faactm.info@faacgroup.com
www.faac-tubularmotors.com

BENELUX

FAAC BENELUX NV/SA
Brugge, Belgium
tel. +32 50 320202
fax +32 50 320242
www.faacbenelux.com

FAAC TUBULAR MOTORS

Transportweg 12
7007 CN Doetinchem
tel. +31 475 406014
fax +31 475 406018
faactm.info@faacgroup.com
www.faac-tubularmotors.com

BRAZIL

INDÚSTRIAS ROSSI ELETROMECÂNICA SA
Brasília DF, Brazil
tel. +55 61 33998787
fax +55 61 34046020
www.rossiportoes.com.br

CHINA

FAAC SHANGHAI
Shanghai, China
tel. +86 21 68182970
fax +86 21 68182968
www.faacgroup.cn

FRANCE

FAAC FRANCE
Saint Priest - Lyon, France
tel. +33 4 72218700
fax +33 4 72218701
www.faac.fr

FAAC FRANCE - AGENCE PARIS

Massy - Paris, France
tel. +33 1 69191620
fax +33 1 69191621
www.faac.fr

FAAC FRANCE - DEPARTEMENT VOLETS

Saint Denis de Pile - Bordeaux, France
tel. +33 5 57551890
fax +33 5 57742970
www.faac.fr

GERMANY

FAAC GMBH
Freilassing, Germany
tel. +49 8654 49810
fax +49 8654 498125
www.faac.de

FAAC TUBULAR MOTORS

tel. +49 30 56796645
fax +49 30 22409006
faactm.info@faacgroup.com
www.faac-tubularmotors.com

INDIA

FAAC INDIA PVT. LTD
Noida – Delhi, India
tel. +91 120 3934100/4199
fax +91 120 4212132
www.faacindia.com

IRELAND

NATIONAL AUTOMATION LTD
Co. Roscommon, Ireland
tel. +353 71 9663893
fax: +353 71 9663890
www.nal.ie

MIDDLE EAST

FAAC MIDDLE EAST FZE
Dubai Silicon Oasis Operation Center - Dubai, UAE
tel. + 971 4 3724190
fax+ 971 4 3724191
www.faac.ae

THE NETHERLANDS

KEMKO BV
Doetinchem, Netherlands
tel. +31 314 378777
fax +31 314 362224
www.kemko.nl

NORDIC REGIONS

FAAC NORDIC AB
Perstorp, Sweden
tel. +46 435 779500
fax +46 435 779529
www.faac.se

POLAND

FAAC POLSKA SP.ZO.O
Warszawa, Poland
tel. +48 22 8141422
fax +48 22 8142024
www.faac.pl

RUSSIA

FAAC RUSSIA
Moscow, Russia
tel. +7 (495) 646 24 29
www.faac.ru

SPAIN

CLEM, S.A.U.
San Sebastián de los Reyes - Madrid, Spain
tel. +34 91 3581110
fax +34 91 7293309
www.faac.es

SWITZERLAND

FAAC AG
Altdorf, Switzerland
tel. +41 41 8713440
fax +41 41 8713484
www.faac.ch

TURKEY

FAAC OTOMATİK GEÇİŞ SİSTEMLERİ
SAN. VE TİC. LTD. SIRTEKİ
İstanbul, Turkey
tel.+90 (0)212 - 3431311
www.faac.com.tr

UNITED KINGDOM

FAAC UK LTD.
Basingstoke Hampshire, UK
tel. +44 1256 318100
fax +44 1256 318101
www.faac.co.uk

U.S.A.

FAAC INTERNATIONAL INC
Rockledge, FL - U.S.A.
tel. +1 866 925 3222
fax +1 904 448 8958
www.faacusa.com

FAAC INTERNATIONAL INC
Fullerton, California - U.S.A.
tel. +1 714 446 9800
fax +1 714 446 9898
www.faacusa.com



In order to improve its products continuously, FAAC S.p.A. reserves the right to make technical modifications without prior notice. All rights are reserved and reproduction in any form, using any means, of part or all of this document is forbidden without the written authorisation of FAAC S.p.A.

9900000314 - Rev. 10/12/2014



617: The new electromechanical barrier. Simplicity in motion.



FAAC

Simply automatic.

617: The simple, reliable electromechanical barrier



Irreversible electromechanical operator

The irreversible motor guarantees holding of the boom position to prevent break-in attempts.

Rapid conversion from right to left version

Changing the opening side is an easy task and can be carried out directly on-site. No need to keep multiple products in stock.

Solid, sturdy body

The weather-resistant steel body is treated with cataphoresis and polyester powder paint finish.

Ideal for medium transit frequency passageways and for controlling access to small or medium-size private areas and car parks.

With its flexible length up to 7 metres long and 2.5 second opening time the barrier is ideal for residential applications, condominiums and small car parks.

Manual release with spanner

Releasing the barrier is easy simply by using a spanner.

Automatic set-up through self-learning

Setting up the barrier for operation is very quick and extremely easy with the self-learning function.

Compatible with rectangular and round booms, optional indicator lights

The 617 is compatible with existing rectangular or round FAAC booms; the latter are suitable for installing lights suitable for installing integrated beam lights.

Easy installation

The large power cable routing hole, the removable side hatch and the ample operating space inside make installation easy and very fast.

Adjustable opening and closing deceleration, smooth movements

Electric limit switches and mechanical stops for adjusting the end of the opening and closing strokes ensure smooth boom movements.

Large internal space to facilitate installation and arrangement of accessories

Plenty of free space is provided inside to allow a high degree of freedom for housing accessories and for installation.

Preset logic electronics for quick, user-friendly barrier configuration

The control board has no fewer than seven preset boom operating logics to choose from. No manual parameter setting is needed.

DIMENSIONS AND TECHNICAL SPECIFICATIONS

MODEL	617		
	3	4	6
Power supply voltage	230 V~, 50/60 Hz		
Electric motor	Electromechanical, grease-lubricated		
Power consumption (W)	315	380	
Absorbed current (A)	1.1	1.7	
Thermal protection (°C)	140		
Capacitor (µF)	12.5		
Effective torque (Nm)	60	100	150
Opening time (s)	2.5	5	8
Max. boom length (m)	3	5	7
Type and frequency of use at 20°C	S3 - 50%	S3 - 60%	
Ambient temperature (°C)	-20	+55	
Operator weight (kg)	63	69	
IP protection rating	IP 44		
Electronic board	615BPR		
Cabinet colour	Grey (RAL 9006)		
Cabinet size (mm)	360x210x1085 (booms up to 5 m long) 410x210x1085 (booms up to 7 m long)		
Boom type	Compatible with current FAAC round and rectangular booms		
Lights on boom	Yes, with round booms only (optional)		

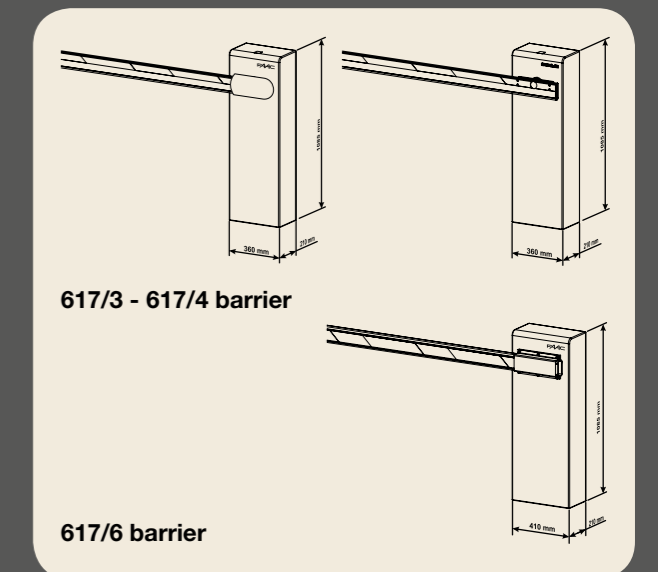

SPECIFIC ACCESSORIES FOR ROUND BOOMS



■ Boom light connection kit ■ Luminous cord 5 m

SPECIFIC ACCESSORIES FOR RECTANGULAR BOOMS



■ Articulation kit