

# 402

for residential swing gates  
with single-leaf length of 1.8 m (402 CBC) and 3 m (402 SBS)



## ■ The hydraulic system ideal for residential gates

Quick and easy to install, the FAAC 402 system is the most practical and economic choice for residential gates of up to 1.8 metres in length per leaf. The FAAC 402 hydraulic device requires little maintenance and is low on electrical power consumption.

## ■ Maximum safety

The exclusive hydraulic device, ensuring maximum anti-crushing protection, features two highly sensitive by-pass valves. In case of an emergency, the release key makes it possible to operate the gate manually.

## ■ Low noise and reliability requiring little space

Few components and the use of hydraulic oil as motor fluid are the secrets ensuring very quiet movement and reliability under all atmospheric conditions and in an outdoor temperature range of -40°C to +55°C. Thanks to its compact size, FAAC 402 can be installed even when space is at a premium.

## ■ FAAC quality guaranteed through time

On top of the undisputed advantages of FAAC's hydraulic system, there is also a corrosion proof coating highly resistant to atmospheric agents with guaranteed long-life.



- 1 Oil tank
- 2 By-pass valves (cannot be accessed thanks to the supplied "tamper-proof" system)
- 3 Emergency release
- 4 Rod protective housing

FAAC

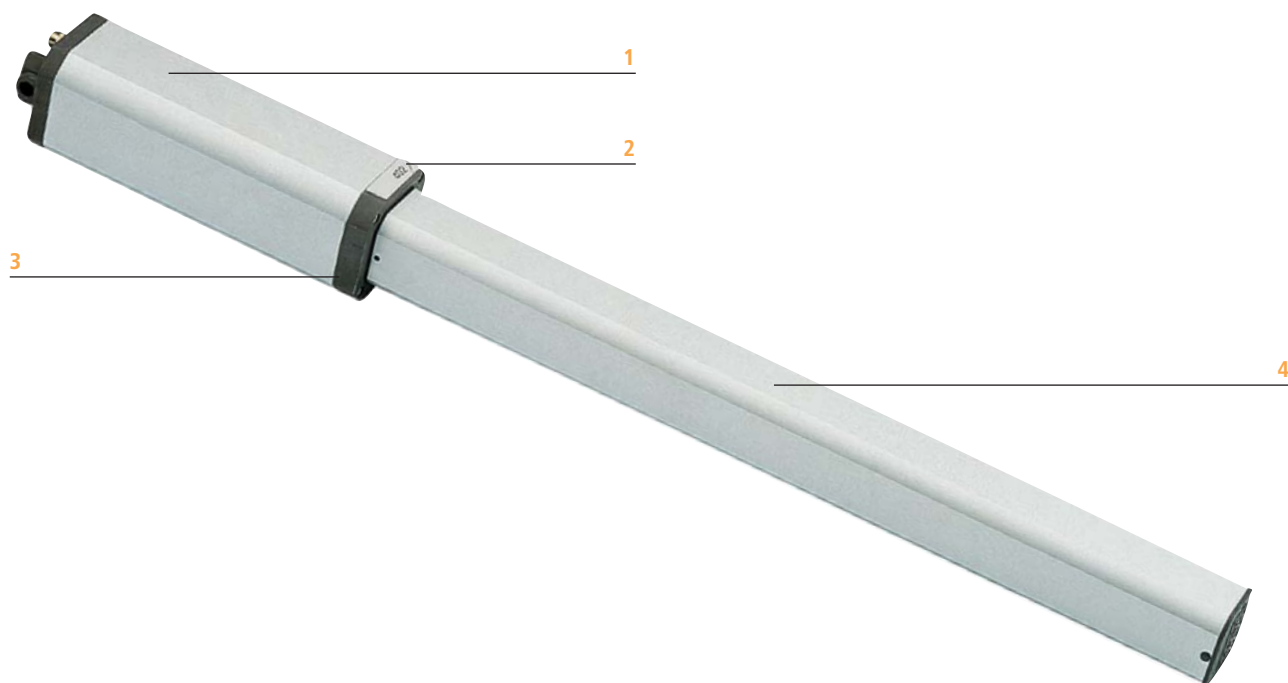

#### DIMENSIONS

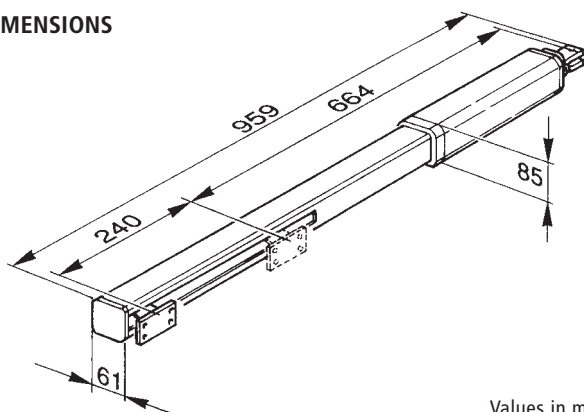

Values in mm

Technical specifications	402 CBC	402 SBS
Power supply	230 Vac (+6% -10%) 50 (60) Hz	
Absorbed power	220 W	
Absorbed current	1 A	
Motor rotation speed	1400 rpm	
Rod extension speed	1.3 cm/s	1 cm/s
Pump flow rate	1 l/min.	0,75 l/min
Traction and thrust force	0÷500 daN	0÷690 daN
Operating ambient temperature	-40°C ÷ +55°C	
Thermal protection on motor winding	120°C	
Weight	6.5 kg	
Type of oil	FAAC HP OIL	
Protection class	IP 55	

Model	Use	
	Single leaf max length (m)	Use frequency (cycles/hour)
402 CBC	1,80	55
402 SBS	3,00	55